

WELLNESSmats®

FOR WORK. FOR LIFE.

WellnessMats Wall Station Assembly Instructions

Compatible with all FitnessMats and MobileMats

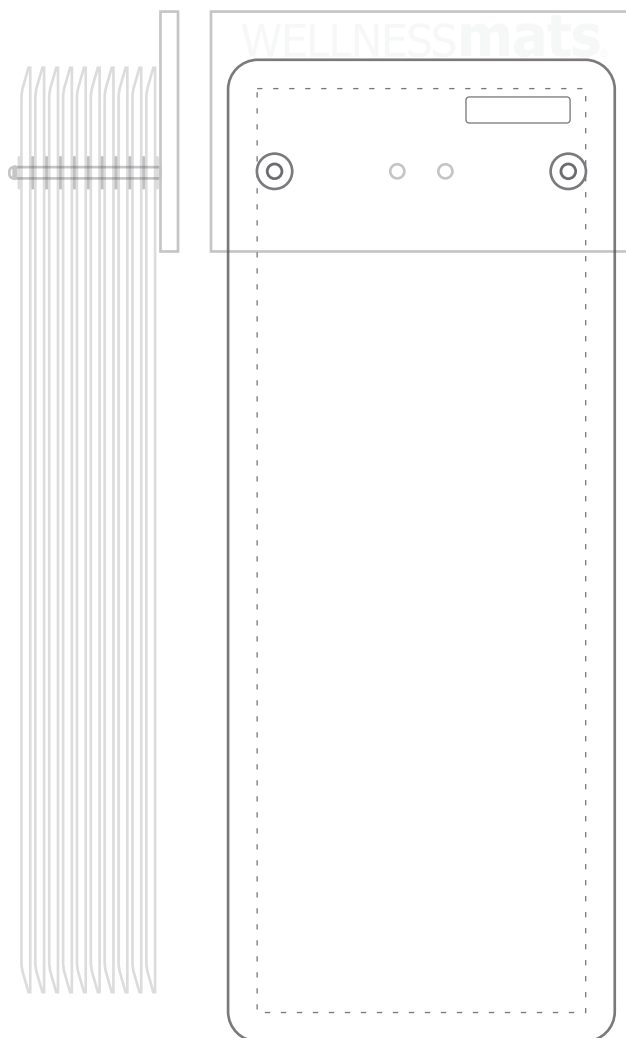





TOOLS REQUIRED

Not Included

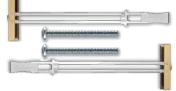
- Electric Hand Drill
- 3/8" Magnetic Hex Driver Bit
- Level
- Stud Finder
- Tape Measure
- Socket and Wrench Set

HARDWARE INCLUDED

Qty	Image	Description
6		#14 x 3" Lag Bolt
2		Toggle Anchor w/Machine Screws
2		1/2" Spring Lock Washer
2		3/8"-16 x 1" Truss Head Screw
2		Standard Washer
2		3/8"-16 x 3/4" Truss Head Screw

STATION PARTS

Qty	Image	Description
2		Hanging Rod
1		Mounting Bracket
1		Station Board

STEP 01

Use a stud finder to locate 2 adjacent studs in the wall. Center the Mounting Bracket to the studs and mount the Mounting Bracket to the wall.



Station must be secured to studs. Insecure Mounting may cause equipment failure, damage, or bodily injury.

For Wood Studs: Attach using (4) #14 x 3" Lag Bolts. Ensure bolts are screwing into wood framing.

For Metal Studs: High-strength toggle anchors have been provided with philips head machine screws. Follow the instructions in anchor packaging.

Ensure anchors are seated firmly into the metal studs.

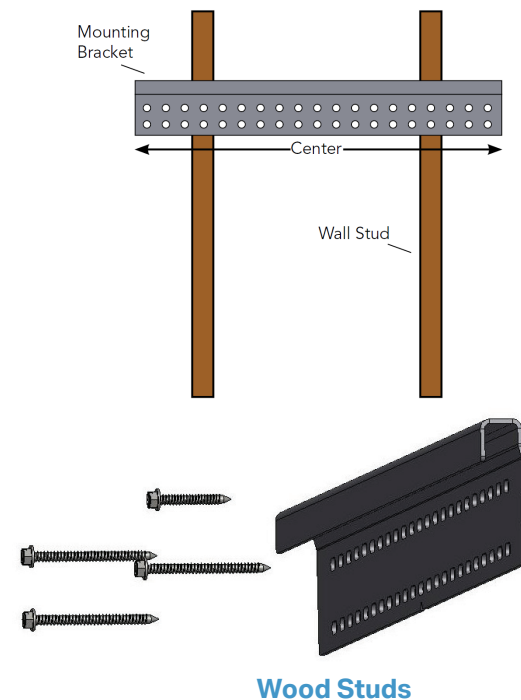

STEP 02

Attach the mat hanging rods to the face of the Station Board. Insert the hanging rod into the face of the board and attach from the back.

Each of the rods will attach with (1) 3/8"-16 X 1" long Truss Head Screw and (1) spring lock washer.

Fully tighten.

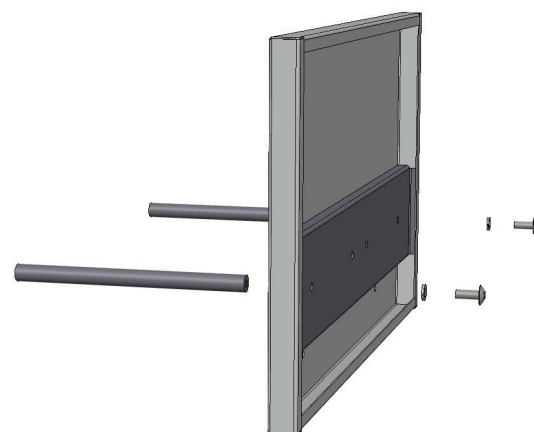

Use the Outermost Holes for FitnessMats, and the Innermost Holes for MobileMats

STEP 03

Carefully lift the Station Board onto the wall bracket. Lift the board against the wall and slightly higher than the bracket. Lower the board straight down so it hooks into the top of the bracket.

Before letting go, be sure the board is hooked.

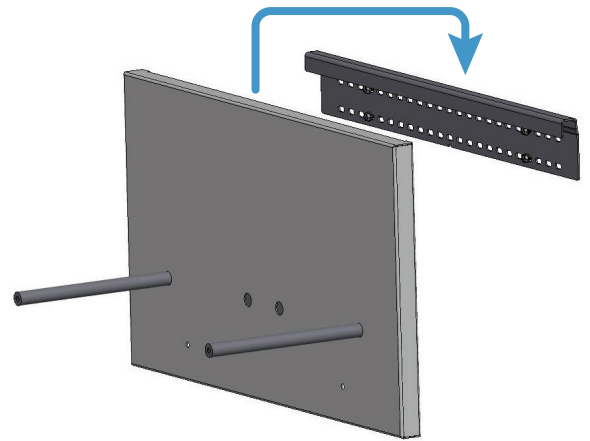

STEP 04

Finish attaching to the wall using the Station Board's lower mounting holes.

You may need to mark holes, remove the board and pre-drill/install hardware as necessary as was done during Step 1.

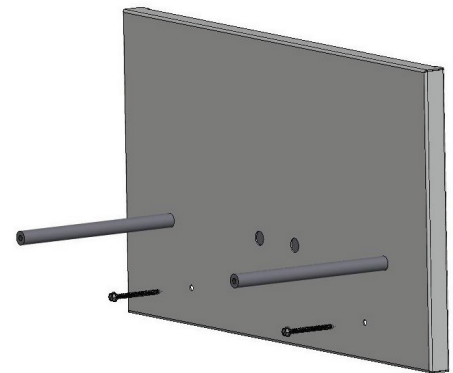

STEP 05

Insert (1) 3/8"-16 X 3/4" long Truss Head Screws and washer spacer into the ends of the mat hanging rods.

Fully tighten.

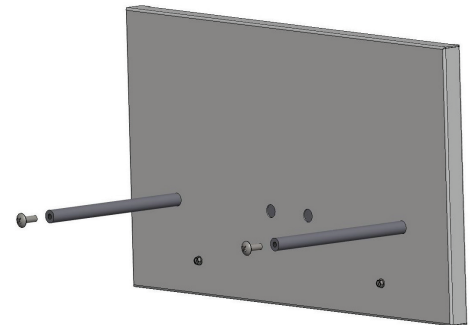

STEP 06

Once the assembly is fully attached mats can now be hung from the rods.

Your Station is now ready to use!

Need Help?

*For questions or customer service:
Call: 1-800-981-4979*